

**Modular Cooking Range Line
 thermaline 90 - Half Module
 Freestanding Gas Fry Top, 1 Side, H=700**

ITEM # _____

MODEL # _____

NAME # _____

SIS # _____

AIA # _____



- | | |
|----------------------------|---|
| 589536 (MCHAEADDPO) | Gas Fry Top with smooth chrome Plate, one-side operated |
| 589544 (MCHCEADDPO) | Gas Fry Top with ribbed chrome Plate, one-side operated |

Short Form Specification

Item No. _____

Unit constructed according to DIN 18860_2 with 20 mm drop nose top and 70 mm recessed plinth. Internal frame for heavy duty sturdiness in stainless steel. 2 mm top in 1.4301 (AISI 304). Flat surface construction, easily cleanable. THERMODUL connection system enables seamless worktop when units are connected and avoids soil penetrating. Chromium-plated mild steel cooking surface with non-stick finishing for optimal grilling. Features safety thermostat, thermostatic control and led indication of pilot flame. Electrical ignition powered by battery with thermocouple for added safety. Large drain hole allows draining of cooking juices into a large collector. Overheat protection switches off the supply in case of overheating. Metal knobs with embedded hygienic silicon "soft" grip enable easier handling and cleaning. IPX5 water resistant certification. Configuration: Freestanding, One-side operated.

Main Features

- Large drain hole on cooking surface permits the draining of residual cooking juices into a large collector placed under the cooking surface.
- Overheat protection: the temperature sensor switches off the supply in case of overheating.
- Safety thermostat and thermostatic control.
- Stainless steel high splash guards on the rear and sides of cooking surface.
- Units have separate controls for each half module of the cooking surface.
- All major components may be easily accessed from the front.
- THERMODUL connection system creates a seamless work top when units are connected to each other thus avoiding soil penetrating vital components and facilitating the removal of units in case of replacement or service.
- Metal knobs with embedded hygienic "soft-touch" grip for easier handling and cleaning. The special design of the controls prevents infiltration of liquids or soil into vital components.
- Large visible digital display manufactured in tempered glass to resist heat and chemicals, showing temperatures or power settings. The display also shows on/off status of the appliance and on/off status of the heating elements.
- Electrical ignition powered by battery with thermocouple for added safety.
- Led indication of pilot flame

Construction

- 2 mm top in 1.4301 (AISI 304).
- Unit constructed according to DIN 18860_2 with 20 mm drop nose top and 70 mm recessed plinth.
- Flat surface construction with minimal hidden areas to easily clean all surfaces
- Cooking surface in chromium-plated mild steel with non-stick finishing for optimum grilling results.
- IPx4 water protection.
- Internal frame for heavy duty sturdiness in stainless steel.
- Cooking surface to be completely smooth or completely ribbed.

APPROVAL: _____

Optional Accessories

- Connecting rail kit, 900mm PNC 912502
- Stainless steel side panel, 900x700mm, freestanding PNC 912512
- Stainless steel front kicking strip, 400mm width PNC 912630
- Stainless steel side kicking strip left and right, freestanding, 900mm width PNC 912657
- Stainless steel side kicking strip left and right, back-to-back, 1810mm width PNC 912663
- Stainless steel plinth, freestanding, 400mm width PNC 912954
- Connecting rail kit: modular 90 (on the left) to ProThermetic tilting (on the right), ProThermetic stationary (on the left) to ProThermetic tilting (on the right) PNC 912975
- Connecting rail kit: modular 80 (on the right) to ProThermetic tilting (on the left), ProThermetic stationary (on the right) to ProThermetic tilting (on the left) PNC 912976
- Endrail kit, flush-fitting, left PNC 913111
- Endrail kit, flush-fitting, right PNC 913112
- Scraper for smooth plates (only for 589536) PNC 913119
- Scraper for ribbed plates (only for 589544) PNC 913120
- Endrail kit (12.5mm) for thermaline 90 units, left PNC 913202
- Endrail kit (12.5mm) for thermaline 90 units, right PNC 913203
- Stainless steel side panel, left, H=700 PNC 913222
- Stainless steel side panel, right, H=700 PNC 913223
- T-connection rail for back-to-back installations without backsplash (to be ordered as S-code) PNC 913227
- Insert profile d=900 PNC 913232
- Perforated shelf for warming cabinets and cupboard bases (one-side operated TL80-85-90 and two-side operated for TL80) PNC 913233
- Endrail kit, (12.5mm), for back-to-back installation, left PNC 913251
- Endrail kit, (12.5mm), for back-to-back installation, right PNC 913252
- Endrail kit, flush-fitting, for back-to-back installation, left PNC 913255
- Endrail kit, flush-fitting, for back-to-back installation, right PNC 913256
- Side reinforced panel only in combination with side shelf, for freestanding units PNC 913260
- Side reinforced panel only in combination with side shelf, for back-to-back installations, left PNC 913275
- Side reinforced panel only in combination with side shelf, for back-to-back installation, right PNC 913276
- Shelf fixation for TL80-85-90 one-side operated, TL80 two-side operated PNC 913279
- Stainless steel dividing panel, 900x700mm, (it should only be used between Electrolux Professional thermaline Modular 90 and thermaline C90) PNC 913672
- Stainless steel side panel, 900x700mm, flush-fitting (it should only be used against the wall, against a niche and in between Electrolux Professional thermaline and ProThermetic appliances and external appliances - provided that these have at least the same dimensions) PNC 913688

Recommended Detergents

- C41 HI-TEMP RAPID DEGREASER, 1 pack of six 1 lt. bottles (trigger incl.) PNC 0S2292



Electrolux
PROFESSIONAL

**Modular Cooking Range Line
thermaline 90 - Half Module
Freestanding Gas Fry Top, 1 Side, H=700**

Gas

Gas Power: 10 kW
Gas Type Option:
Gas Inlet: 1/2"

Key Information:

Cooking Surface Depth: 615 mm
Cooking Surface Width: 300 mm
Working Temperature MIN: 110 °C
Working Temperature MAX: 270 °C
External dimensions, Width: 400 mm
External dimensions, Depth: 900 mm
External dimensions, Height: 700 mm
Storage Cavity Dimensions (width): 340 mm
Storage Cavity Dimensions (height): 330 mm
Storage Cavity Dimensions (depth): 740 mm
Net weight: 91 kg
Configuration: On Base;One-Side Operated
Cooking surface type:
589536 (MCHAEADDPO) Smooth
589544 (MCHCEADDPO) Ribbed
Cooking surface - material: Chromium Plated mild steel mirror

Front

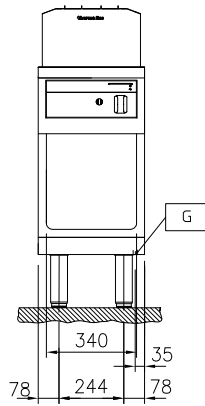

Front

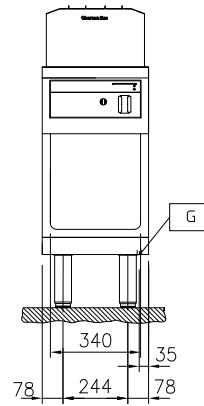

Side

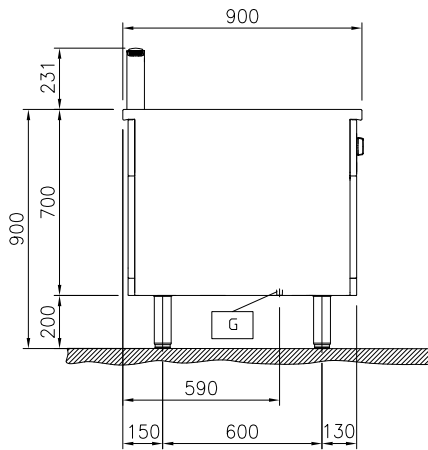

Side

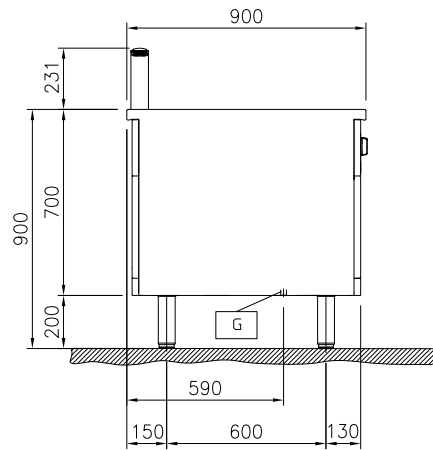

EQ = Equipotential screw
G = Gas connection

EQ = Equipotential screw
G = Gas connection

Top

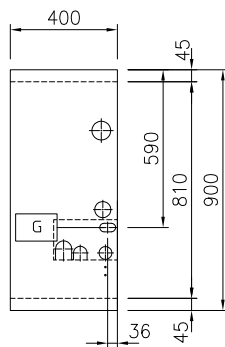

Top

